

Semi-Electric Bed

User Manual & Entrapment Guide

For use with Item #'s

HBSMBEM

HBSMSS



TABLE OF CONTENTS

User Manual	4 — 11
Special Notes	4
Warnings	4
Indications for Use	4
Frame Assembly Instructions	5
Bed Assembly Instructions	6
Drive Shaft Assembly	6 – 7
Bed Operation	7 – 9
Pendant Hand Control	7
Motor Assembly	8
Crank Operation	9
Head/Foot Board Height Adjustment	10
Specifications	10
Maintenance and Safety Checks	11
Electronics	11
Bed Frame and Sleeping Surface	11
Cleaning	11
Lubrication and Mechanical	11
Warranty	11
Entrapment Guide	12 — 19
Key Body Parts at Risk	12
Head	12
Neck	12
Chest	12
Potential Zones of Entrapment	13
Dimensional Limits for Identified Entrapment Zones.	13 — 17
A Guide to Bed Safety	17
Meeting Patients' Needs for Safety	18
Patient or Family Concerns about Bedrail Use	19

WARNINGS

PLEASE READ ALL WARNINGS/CAUTIONS BEFORE USE

- Your Manual/ Electric bed has been totally engineered to provide you with reliable operation and the strength you deserve.
- The bed has been thoroughly tested and inspected prior to shipment.
- The utmost in comfort and safety has been provided for you. The bed is for your HOME use only.
- It is NOT for hospital use and was not designed to meet hospital standards.
- DO NOT use near explosive gases.
- Possible fire hazard when used with oxygen administering equipment other than nasal or masked type.
- When using nasal or masked type administering equipment, oxygen or air tubing MUST be routed and secured properly to ensure that tubing does NOT become entangled and eventually severed during normal operation of Manual/ Electric bed.
- When using liquids in or around the bed, caution should be taken to ensure that liquids of any kind are not spilled in or around the bed.
- If a spill occurs, UNPLUG the bed immediately.
- Clean up spill and allow bed or area to dry thoroughly before using the electric controls again.
- Close supervision is necessary when this product is used by or near CHILDREN OR PHYSICALLY CHALLENGED INDIVIDUALS.
- This product should never be left unattended when plugged in.
- NEVER PERMIT ANY ONE UNDER THE BED AT ANYTIME.
- When operating or moving the bed, ALWAYS ensure that the individual utilizing the bed is positioned properly within the confines of the bed.
- DO NOT let any extremities protrude over the side or between the bed rails when performing these functions.

SPECIAL NOTES

NOTICE:

- The information contained in this document is subject to change without notice.
- WARNINGS/CAUTION notices used in this manual apply to hazards or unsafe practices which could result in personal injury and/or property damage.
- Check all parts for shipping damage and test before using. In case of a damage, do NOT use.
- Contact the dealer for further instruction.

INDICATIONS FOR USE

A home care bed is intended to provide assistance to a patient and/ or their caregiver for proper positioning of patients with long-term and permanent illnesses, injuries or disabilities such as:

- It is necessary to elevate the head of the bed 30 or more degrees most of the time due to, but not limited to, congestive heart failure, chronic pulmonary disease, or problems with aspiration
- Patient requires special attachments, such as traction equipment, that can only be attached to a hospital bed
- Patient requires an adjustable bed to permit transfers to chair, wheelchair, or standing position. This includes, but is not limited to:
- Severe arthritis and other injuries to lower extremities
- Spinal cord injuries (including quadriplegia and paraplegia), muscular dystrophies, multiple limb amputations, and stroke, where the patient is able to transfer from a bed to a wheelchair with or without help
- Patient requires frequent changes in body position or might require an immediate need for a change in body position to avert a life threatening situation.

FRAME ASSEMBLY INSTRUCTIONS

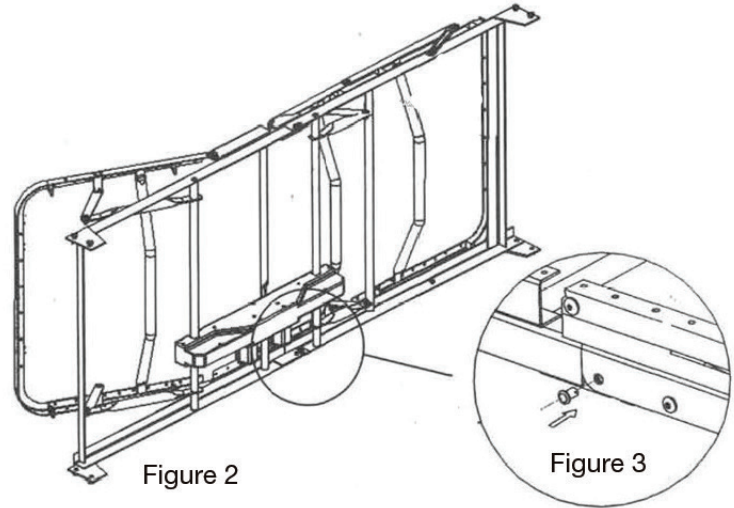
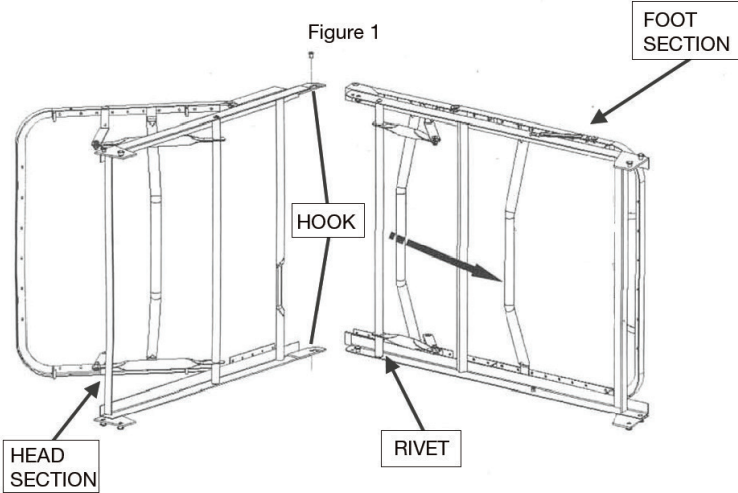

NOTE: Spring fabric not shown for clarity

- Lay the head and foot section on their sides approximately 90° to each other (See Figure 1).
- Slide the sections together until the hook on the foot section catches the rivet on the head section.
- Straighten sections and position as shown in figure 2.
- Position head wing as shown.
- With the two sections level, install a frame lock pin into each side of the frame as shown in figure 3.
- Be sure to properly install frame lock pins before use

- **NOTE:** Lock pins must be installed to ensure safe operation/use
- Attach fabric halves together using spring clips, which are attached to the foot fabric. (See Below)

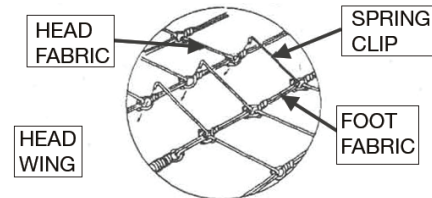

BED ASSEMBLY INSTRUCTIONS

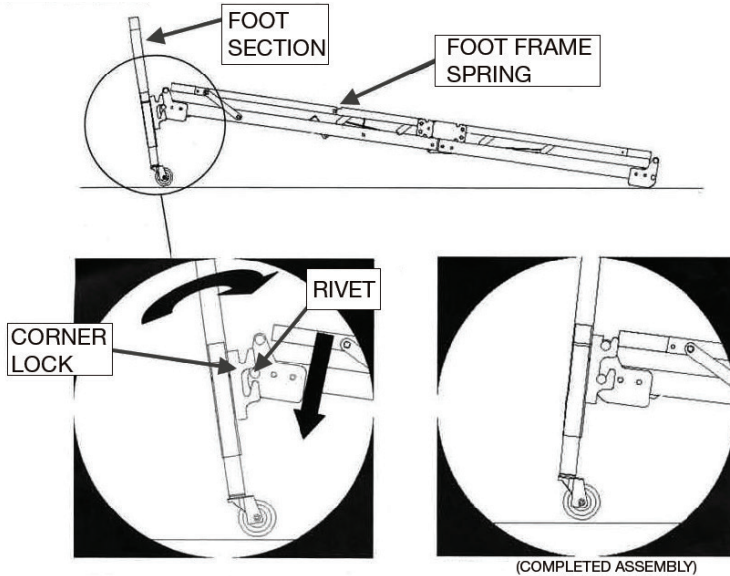

- Standing directly in front of the bed end, position it as close to the bed as possible.
- With one hand reach over end and lift up bed.
- Tilt the bed end slightly back toward you.
- Engage lower rivet slightly and tilt end toward bed.
- Lower bed into corner lock.
- Repeat for head end.

DRIVE SHAFT ASSEMBLY

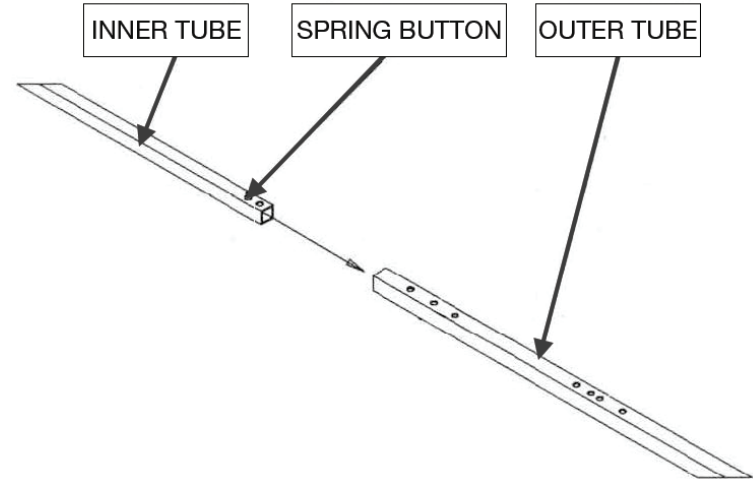

- The drive shaft is comprised of two sections — inner and outer tubes.
- Depress spring button and insert until desired hole is reached.

DRIVE SHAFT ASSEMBLY (CONT.)

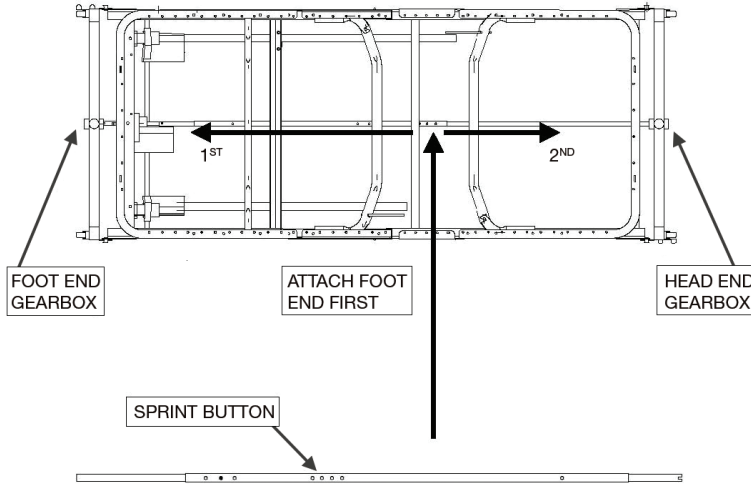

- Connect the drive shaft assembly to the bed by first attaching either side of the drive shaft to the foot end gearbox. Then attach other end to head end gearbox.

BED OPERATION — PENDANT HAND CONTROL

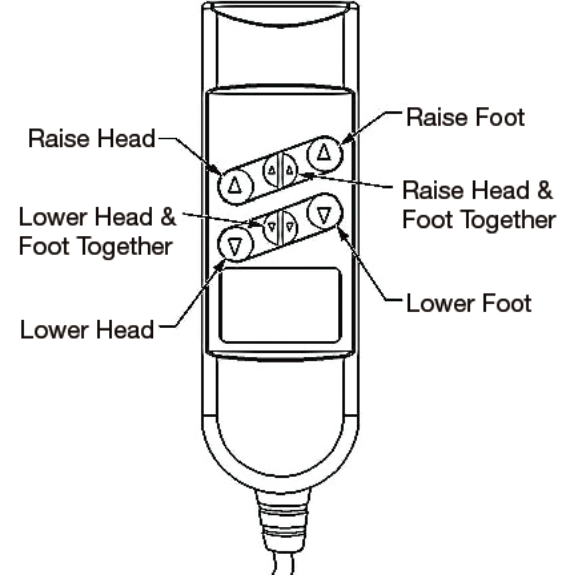

- In the event of a power failure, use a standard 9V battery to lower the bed's head and foot sections.
- When used with the battery, the motor will only lower, not lift, the head and/or foot sections.

BED OPERATION (CONT.) — MOTOR ASSEMBLY

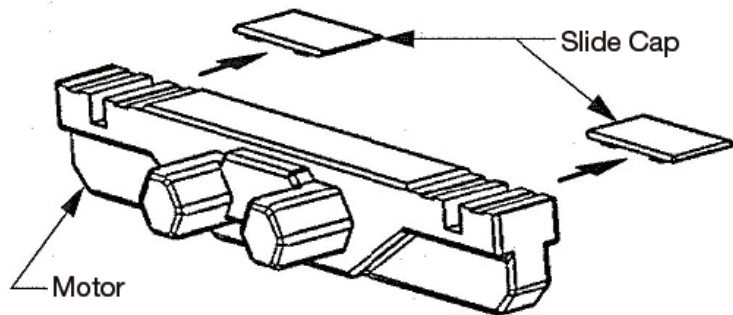

Remove Motor Side Caps

- Remove the slide caps from both ends of the motor as shown below.
- Plungers should be recessed in motor cavities; if not, operate the "down" function on the pendant hand control until plunger is recessed.

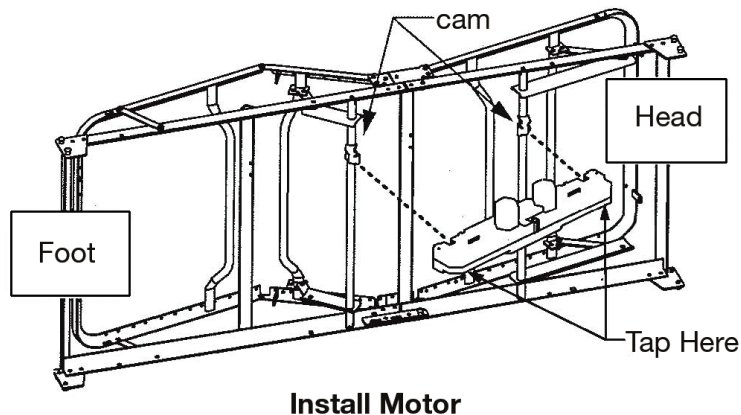

Install Motors

- Hold the bed securely, positioned with motor cams up, as shown below.
- Position the motor over both cams
- Tap either end of the motor housing (shown below) with enough force to snap the motor assembly into position on the cam.
- Repeat for other end of motor.

NOTE: This is a bearing surface requiring a tight fit; it may require a hardy hit with palm of hand to snap over motor tube.

BED OPERATION (CONT.) — CRANK OPERATION

Use the crank at the center of the foot board of the semi-electric bed to change the entire deck height.

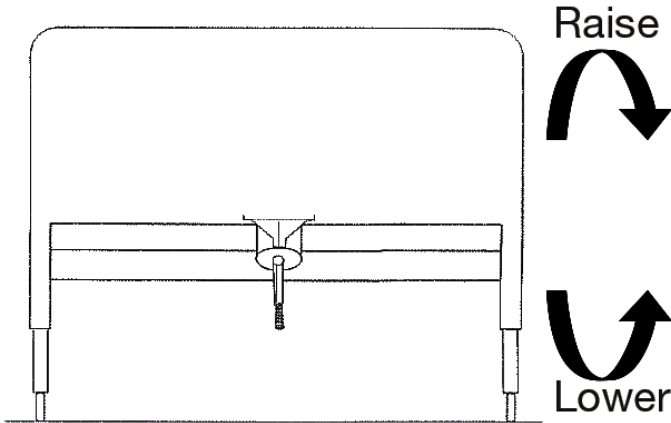

To raise bed – Turn the crank handle clockwise.

To lower bed – Turn the crank handle counter-clockwise.

Trendelenberg position

- 1) Lower bed to its lowest height. Disengage the hi/lo rod by compressing the spring fitting and removing the hi/lo rod from the motor or bed end.
- 2) Raise the foot bed end using the pendant hand control or crank (semi-electric bed only).
- 3) The head end will remain in the low position.

Reverse Trendelenberg

- 4) Raise bed to its highest height. Disengage the hi/lo rod by compressing the spring fitting and removing the hi/lo rod from the motor or bed end.
- 5) Lower the foot bed end using the pendant hand control or crank (semi-electric bed only).
- 6) The head end will remain in the high position.

HEAD/FOOT BOARD — OPTIONAL HEIGHT ADJUSTMENT

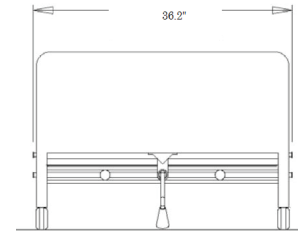
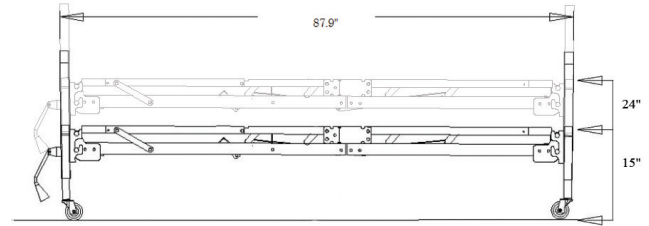
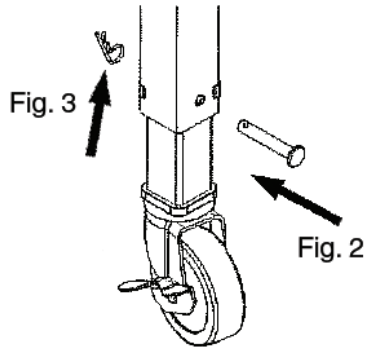
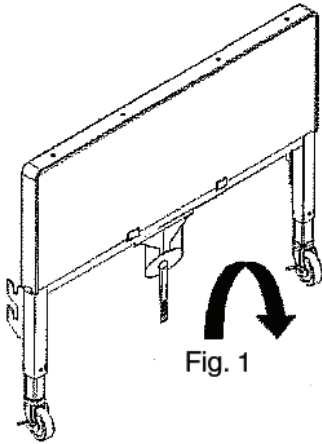

Pin Installation

- Rotate the crank handle clockwise to raise the bed to the desired height. (Fig. 1)
- Insert lock pin through adjustment hole. (1" increments)
NOTE: If lock pin cannot insert through the holes easily, rotate the crank handle (clockwise or counter-clockwise) until the lock pin goes through. (Fig. 2)
- Secure lock pin with safety pin provided. (Fig. 3)
- Repeat on each remaining leg.

SPECIFICATIONS

The deck height of the bed can be adjusted from 15" – 24"

Electrical	Motor is ETL Approved
Weight Capacity	450 lbs.
Construction	Frame: 11ga (.120) hot rolled steel. Sleeping surface: Zinc plated steel wire and coils
Finish	Durable Powder Coating

MAINTENANCE AND SAFETY CHECKS

To be performed once per year or between patient placements.

Electronics

Check all controls to make sure all functions work properly.

- Power cord
- Pendant cord
- Check to make sure all wires are routed and attached properly so they do not interfere with any moving parts.
- Check to make sure all plugs are fully inserted or attached.

Bed Frame and Sleeping Surface

Visually check all welds

- Head section
- Knee section
- Main Frame
- Check joints between sleeping surface sections for loose fasteners.

Cleaning

The metal parts of the bed are covered with a baked epoxy coating. Clean all coated parts with mild detergent and warm water. Periodically raise head and feet sections of the bed and remove dust from frame. Also, periodically remove the mattress and clean mattress deck.

Lubrication and Mechanical

- Lightly grease all actuator screw threads with white lithium grease.
- Lubricate all caster roller and swivel bearings with light machine oil.
- Check all bolts and tighten as needed.

WARRANTY

- Your ProBasics brand product is warranted as follows:
 - Frame – 5 years
 - Motor – 2 years
 - All other parts - 1 year
- This device was built to exacting standards and carefully inspected prior to shipment. This Limited Warranty is an expression of our confidence in the materials and workmanship of our products and our assurance to the end user of years of dependable service.
- This warranty does not cover device failure due to misuse or negligence, or normal wear and tear. The warranty does not extend to non-durable components, such as rubber accessories, casters, and grips, which are subject to normal wear and need periodic replacement.
- If you have questions about your ProBasics device or this warranty, please contact an authorized ProBasics dealer or Compass Health Brands.

ENTRAPMENT GUIDE: BED RAILS IN NURSING HOMES AND THE HOME HEALTH CARE ENVIRONMENT

KEY BODY PARTS AT RISK

Three key body parts at risk for life-threatening entrapment in the seven zones of a hospital bed system discussed in this guidance are the head, neck, and chest.

The body part dimensions used to develop FDA's dimensional limit recommendations are summarized as follows:

Key Body Part	Dimension
Head	120 mm (4-¾ inches)
Neck	60 mm (2-⅜ inches and angle >60°)
Chest	318 mm (12-½ inches)

Head

To reduce the risk of head entrapment, openings in the bed system should not allow the widest part of a small head (head breadth measured across the face from ear to ear) to be trapped.

FDA is therefore using a head breadth dimension of 120 mm (4-¾ inches) as the basis for its dimensional limit recommendations. This dimension is consistent with the dimensions recommended by the HBSW and the IEC.

Neck

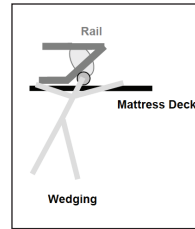

To reduce the risk of neck entrapment, openings in the bed system should not allow a small neck to become trapped.

Given the adult population at risk for wedging entrapments in hospital beds, FDA recommends a dimension of 60 mm (2-⅜ inches) to represent neck diameter.

Additionally, to prevent wedging, a limit of greater than 60° is recommended for V-shaped openings that a neck could enter. These dimensions are consistent with the dimensions recommended by the HBSW and the IEC (see IEC 60601-2-38-1).

Chest

The openings in a bed system should be wide enough not to trap a large chest through the opening between split rails.

FDA concurs with the IEC recommended dimension of 318 mm (12-½ inches) to represent chest depth for the population vulnerable to entrapment, and has used this dimension as the basis for its recommended dimensional limits.

POTENTIAL ZONES OF ENTRAPMENT

This guidance describes seven zones in the hospital bed system where there is a potential for patient entrapment. Entrapment may occur in flat or articulated bed positions, with the rails fully raised or in intermediate positions.

The seven areas in the bed system where there is a potential for entrapment are identified in the drawing below.

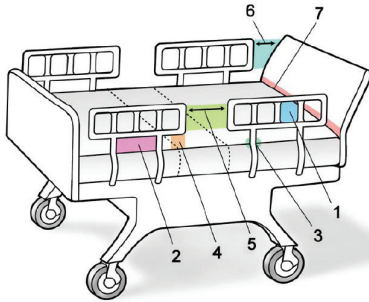

Zone 1	Within the rail.
Zone 2	Under the rail, between the rail supports or next to a single rail support
Zone 3	Between the rail and the mattress
Zone 4	Under the rail, at the ends of the rail
Zone 5	Between split bed ends
Zone 6	Between the end of the rail and the side edge of the head or foot board
Zone 7	Between the head or foot board and the mattress end

DIMENSIONAL LIMITS FOR IDENTIFIED ENTRAPMENT ZONES

Summary of FDA Hospital Bed Dimensions Limit Recommendations

Zone	Dimensional Limit Recommendations
1. Within the rail	< 120 mm (< 4-¾ inches)
2. Under the rail, between rail supports or next to a single rail support	< 120 mm (< 4-¾ inches)
3. Between the rail and mattress	< 120 mm (< 4-¾ inches)
4. Under the rail, at the ends of the rails	<60 mm (< 2-¾") AND > 60° angle

Zone 1 — Within the Rails

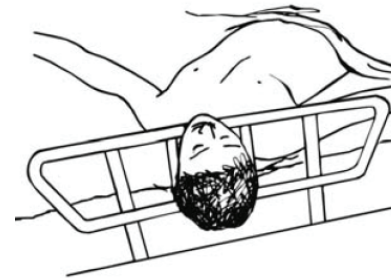

This is any open space within the perimeter of the rail. Openings in the rail should be small enough to prevent the head from entering. A loosened bar or rail can change the size of the space. The HBSW and IEC recommend that the space be less than 120 mm (4-¾ inches), representing head breadth.

Zone 2 — Under the Rail, Between the Rail Supports or Next to a Single Rail Support



This space is the gap under the rail between a mattress compressed by the weight of a patient's head and the bottom edge of the rail at a location between the rail supports, or next to a single rail support. If there is a single rail support, entrapment in Zone 2 can occur anywhere along the bottom length of the rail beyond the support, up to the end of the rail. (Entrapment at the end of the rail is explained in Zone 4.) Factors to consider are the mattress compressibility¹⁷ which may change over time due to wear, the lateral shift of the mattress or rail, and any degree of play from loosened rails or rail supports. A restless patient may enlarge the space by compressing the mattress beyond the specified dimensional limit. This space may also change with different rail height positions and as the head or foot sections of the bed are raised and lowered. The space may increase, decrease, become less accessible, or disappear entirely. In some positions, the potential for entrapment in this zone may still exist when the deck is articulated.

Preventing the head from entering under the rail would most likely prevent neck entrapment in this space. FDA recommends that this space be small enough to prevent head entrapment, less than 120 mm (4 ¾ inches). IEC recommends the same dimensions but measures the space without the mattress in place.

Zone 3 — Between the Rail and the Mattress



This area is the space between the inside surface of the rail and the mattress compressed by the weight of a patient's head. The space should be small enough to prevent head entrapment when taking into account the mattress compressibility, any lateral shift of the mattress or rail, and degree of play from loosened rails. HBSW and IEC recommend a dimension of less than 120 mm (4 ¾ inches) because the head is presumed to enter the space before the neck. FDA is recommending a dimensional limit of less than 120 mm (4 ¾ inches) for the area between the inside surface of the rail and the compressed mattress.

Zone 4 — Under the Rail at the Ends of the Rail



This space is the gap that forms between the mattress compressed by the patient, and the lowermost portion of the rail, at the end of the rail. Factors that may increase the gap size are: mattress compressibility, lateral shift of the mattress or rail, and degree of play from loosened rails. The space poses a risk for entrapment of a patient's neck. It may change with different rail height positions and as the head or foot sections of the bed are raised and lowered. The space may increase, decrease, become less accessible, or disappear entirely. Thus, in some positions, the potential for entrapment in this zone may still exist when the deck is articulated.

At the time of this publication, the IEC international standard recommends a dimensional limit of less than 60 mm (2 3/8 inches) measured between the mattress support platform and the lowest portion of the rail at the rail end to prevent neck entrapment. Based on the neck diameter dimension described above, FDA recommends that the dimensional limit for this space also be less than 60 mm

(2 3/8 inches). To reduce the risk of neck entrapment at Zone 4, FDA recommends consideration of the combination of the gap size and the angle size (created between the mattress and the rail). Thus, FDA recommends that the V-shaped opening under the rail at its end be of an angle wide enough, i.e. greater than 60 degrees, to prevent wedging entrapment

Zone 5, 6 and 7

Although seven potential zones of entrapment have been identified by HBSW, FDA is recommending dimensional limits for zones 1-4 because these zones were most frequently reported as having entrapments.

FDA continues to receive entrapment reports for Zones 5 and 6, and Zone 7 remains a potential for entrapment. FDA will monitor entrapments in these zones and consider harmonization with the IEC standard once it is available.

Zone 5 — Between Split Bed Rails



This zone occurs when partial length head and foot side rails (split rails) are used on the same side of the bed. The space between the split rails may present a risk of either neck entrapment or chest entrapment between the rails if a patient attempts to, or accidentally, exits the bed at this location. In addition, any V-shaped opening between the rails may present a risk of entrapment due to wedging. FDA recognizes this area as a potential for entrapment and encourages facilities and manufacturers to report entrapment events at this zone.

Zone 6 — Between the End of the Rail and the Side Edge of the Head or Foot Board



This is the space between the end of the rail and the side edge of the headboard or footboard. This space may present a risk of either neck entrapment or chest entrapment. In addition, any V-shaped opening between the end of the rail and the head or footboard may present a risk of entrapment due to wedging. This space may change when raising or lowering the head or foot sections of the bed. This space may increase, decrease, become less accessible, or disappear entirely. Thus, in some positions, the potential for entrapment may exist when the deck is articulated. FDA recognizes this area as a potential for entrapment and encourages facilities and manufacturers to report entrapment events at this zone.

Zone 7 — Between the Head or Foot Board and the End of the Mattress



This is the space between the inside surface of the head board or foot board and the end of the mattress. This space may present a risk of head entrapment when taking into account the mattress compressibility, any shift of the mattress, and degree of play from loosened head or foot boards. FDA recognizes this area as a potential for entrapment and encourages facilities and manufacturers to report entrapment events at this zone.

A GUIDE TO BED SAFETY

Bed Rail Entrapment Statistics

Today there are about 2.5 million hospital and nursing home beds in use in the United States. Between 1985 and January 1, 2009, 803 incidents of patients* caught, trapped, entangled, or strangled in beds with rails were reported to the U.S. Food and Drug Administration. Of these reports, 480 people died, 138 had a nonfatal injury, and 185 were not injured because staff intervened. Most patients were frail, elderly or confused.

Patient Safety

Patients who have problems with memory, sleeping, incontinence, pain, uncontrolled body movement, or who get out of bed and walk unsafely without assistance, must be carefully assessed for the best ways to keep them from harm, such as falling. Assessment by the patient's health care team will help to determine how best to keep the patient safe. Historically, physical restraints (such as vests, ankle or wrist restraints) were used to try to keep patients safe in health care facilities. In recent years, the health care community has recognized that physically restraining patients can be dangerous. Although not indicated for this use, bed rails are sometimes used as restraints. Regulatory agencies, health care organizations, product manufacturers and advocacy groups encourage hospitals, nursing homes and home care providers to assess patients' needs and to provide safe care without restraints.

A GUIDE TO BED SAFETY (CONT.)

The Benefits and Risks of Bed Rails

Potential benefits of bed rails include:

- Aiding in turning and repositioning within the bed.
- Providing a hand-hold for getting into or out of bed.
- Providing a feeling of comfort and security.
- Reducing the risk of patients falling out of bed when being transported.
- Providing easy access to bed controls and personal care items.

Potential risks of bed rails may include:

- Strangling, suffocating, bodily injury or death when patients or part of their body are caught between rails or between the bed rails and mattress.
- More serious injuries from falls when patients climb over rails.
- Skin bruising, cuts, and scrapes.
- Inducing agitated behavior when bed rails are used as a restraint.
- Feeling isolated or unnecessarily restricted.
- Preventing patients, who are able to get out of bed, from performing routine activities such as going to the bathroom or retrieving something from a closet.

Which Ways of Reducing Risks are Best?

A process that requires ongoing patient evaluation and monitoring will result in optimizing bed safety. Many patients go through a period of adjustment to become comfortable with new options. Patients and their families should talk to their health care planning team to find out which options are best for them.

MEETING PATIENTS' NEEDS FOR SAFETY

Most patients can be in bed safely without bed rails.

Consider the following:

- Use beds that can be raised and lowered close to the floor to accommodate both patient and health care worker needs.
- Keep the bed in the lowest position with wheels locked.
- When the patient is at risk of falling out of bed, place mats next to the bed, as long as this does not create a greater risk of accident.
- Use transfer or mobility aids.
- Monitor patients frequently.
- Anticipate the reasons patients get out of bed such as hunger, thirst, going to the bathroom, restlessness and pain; meet these needs by offering food and fluids, scheduling ample toileting, and providing calming interventions and pain relief.

When bed rails are used, perform an on-going assessment of the patient's physical and mental status; closely monitor high-risk patients. Consider the following:

- Lower one or more sections of the bed rail, such as the foot rail.
- Use a proper size mattress or mattress with raised foam edges to prevent patients from being trapped between the mattress and rail.
- Reduce the gaps between the mattress and side rails.

PATIENT OR FAMILY CONCERNS ABOUT BED RAIL USE

If patients or family ask about using bed rails, health care providers should:

- Encourage patients or family to talk to their health care planning team to determine whether or not bed rails are indicated.
- Reassure patients and their families that in many cases the patient can sleep safely without bed rails.
- Reassess the need for using bed rails on a frequent, regular basis.

To report an adverse event or medical device problem, please call FDA's MedWatch Reporting Program at 1-800-FDA-1088.

For additional information, visit the FDA's website at:

<http://www.fda.gov/medicaldevices>

For more information regarding this information, contact Beryl Goldman at 610-388-5580 or by email at bgoldman@kcorp.kendal.org. She has volunteered to answer questions.

For information regarding a specific hospital bed, contact the bed manufacturer directly.

DEVELOPED BY THE HOSPITAL BED SAFETY WORKGROUP

Participating Organizations:

- AARP
- ABATort and Insurance Practice Section
- American Association of Homes and Services for the Aging
- American Health Care Association
- American Medical Directors Association
- American Nurses Association
- American Society for Healthcare Engineering of the
- American Hospital Association
- American Society for Healthcare Risk Management
- Basic American Metal Products
- Beverly Enterprises, Inc.
- Care Providers of Minnesota
- Carroll Healthcare
- DePaul College of Law
- ECRI
- Evangelical Lutheran Good Samaritan Society
- Hill-Rom Co., Inc.
- Joint Commission on Accreditation of Healthcare Organizations
- Medical Devices Bureau, Health Canada
- National Association for Home Care
- National Citizens' Coalition for Nursing Home Reform
- National Patient Safety Foundation
- RN+ Systems
- Stryker Medical
- Sunrise Medical, Inc.
- The Jewish Home and Hospital
- Untie the Elderly, The Kendal Corporation
- U.S. Food and Drug Administration

October 2000 (Revised 4/2010)

The information included in this document was taken from the following sources:

Food and Drug Administration. "Hospital Bed System Dimensional and Assessment Guidance to Reduce Entrapment," March, 10, 2006
<http://www.fda.gov/downloads/MedicalDevices/DeviceRegulationandGuidance/GuidanceDocuments/ucm072729.pdf>,
accessed on May 10, 2011.

Hospital Bed Safety Workgroup. "A Guide to Bed Safety," October 2000
<http://www.fda.gov/downloads/MedicalDevices/ProductsandMedicalProcedures/GeneralHospitalDevicesandSupplies/HospitalBeds/ucm125857.pdf>, accessed on May 10, 2011.

 **COMPASSHEALTH**

6753 Engle Road
Middleburg Heights, Ohio 44130
Tel.: (800) 376-7263
www.compasshealthbrands.com
SEMI-BEDS_UM_04_260114 ©2026